

Pipe Range Extender

Assembly Instructions

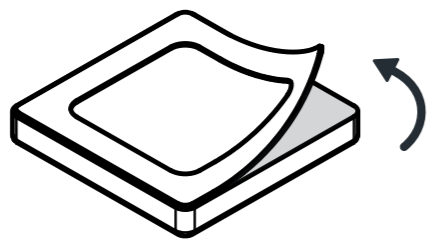

1

Peel the protective film from the back of the sensor.

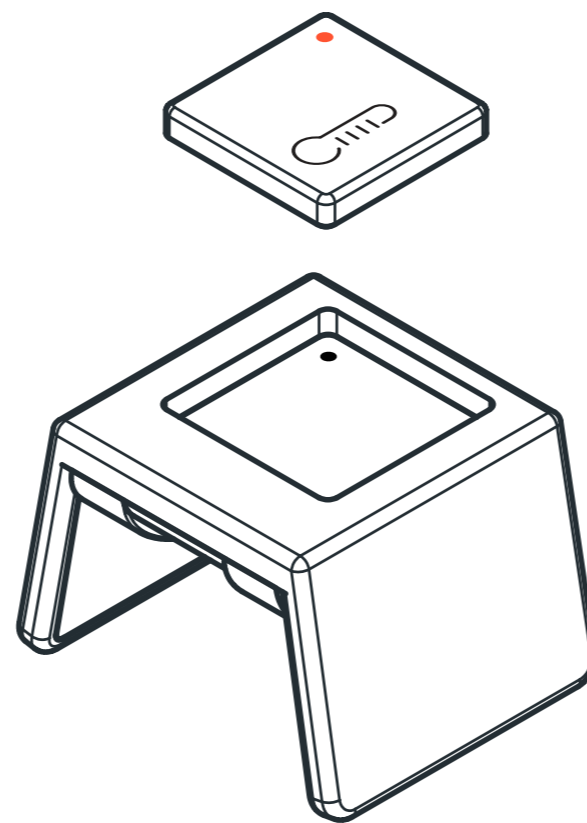

2

Orientation matters: Make sure the dot on the sensor is aligned with the dot on the range extender.

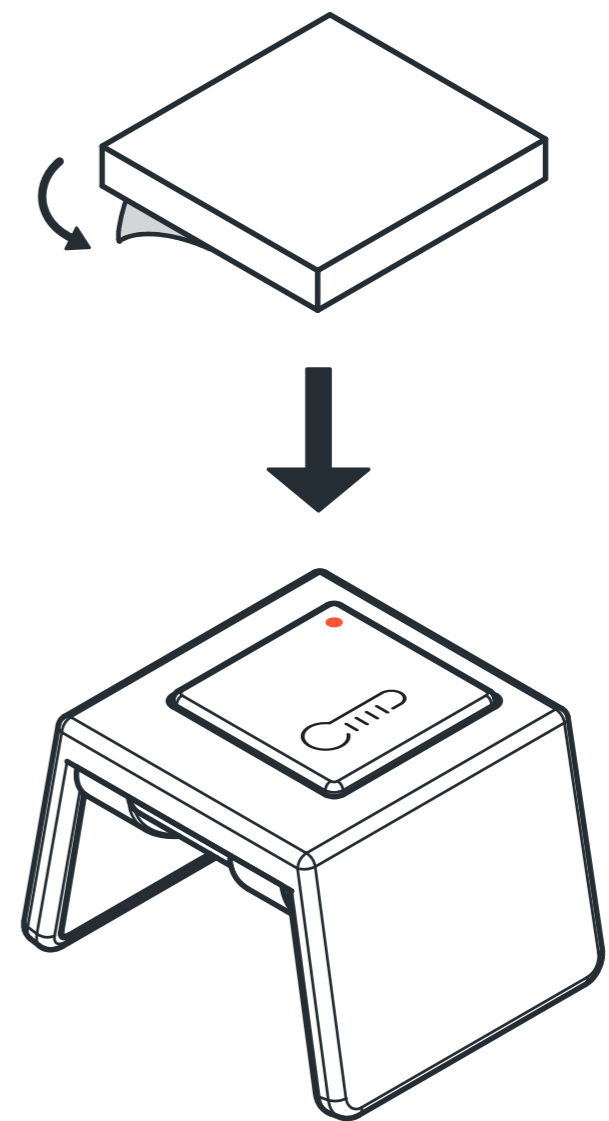

3

Attach the sensor to the range extender and place the thermal pad with the sticky side on top of it.

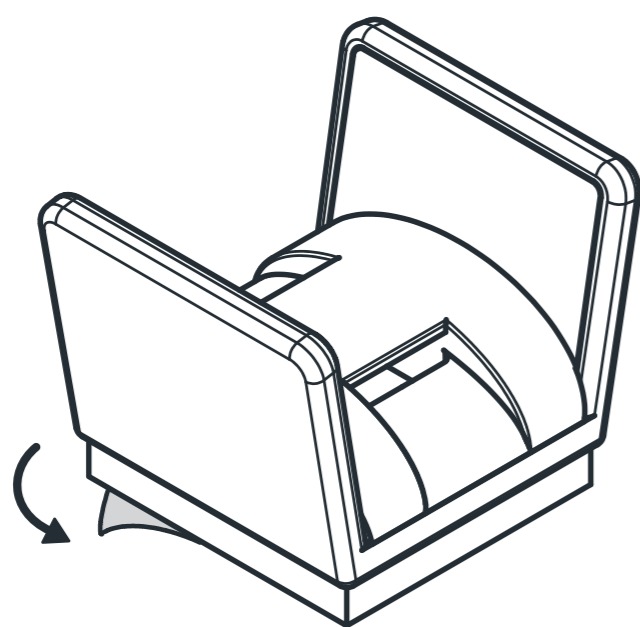

4

Remove the second protective film from the thermal pad.

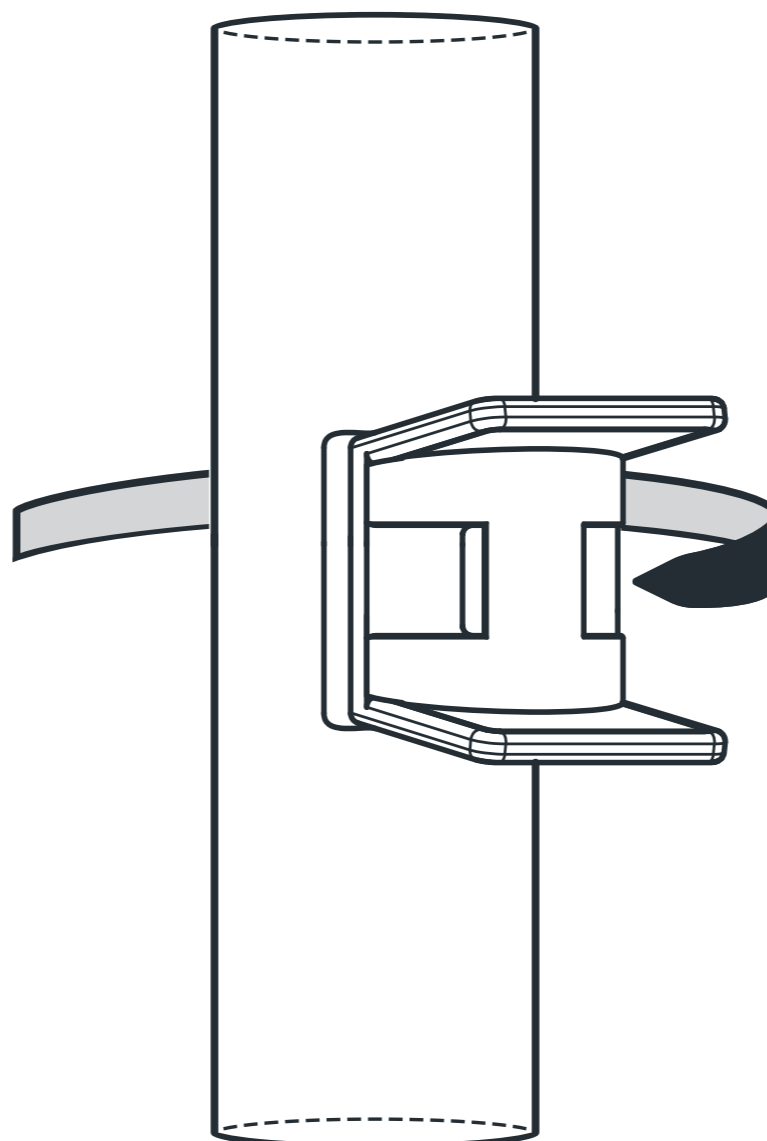

5

Loop the zip tie around the pipe and into the range extender slit.

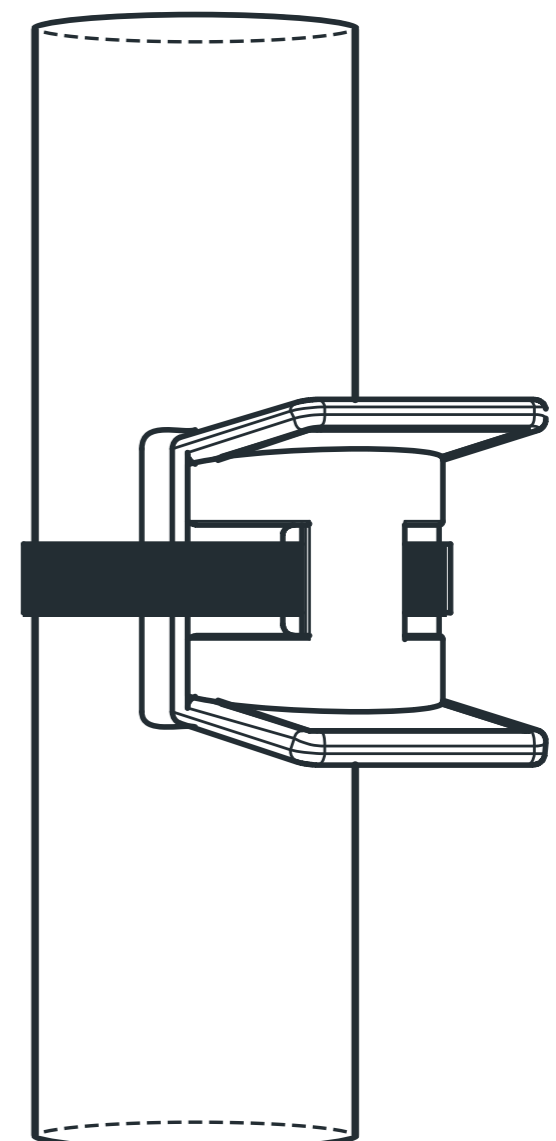

6

Tighten the zip tie firmly to ensure a good thermal transfer between pipe and sensor.